

PREMIERE

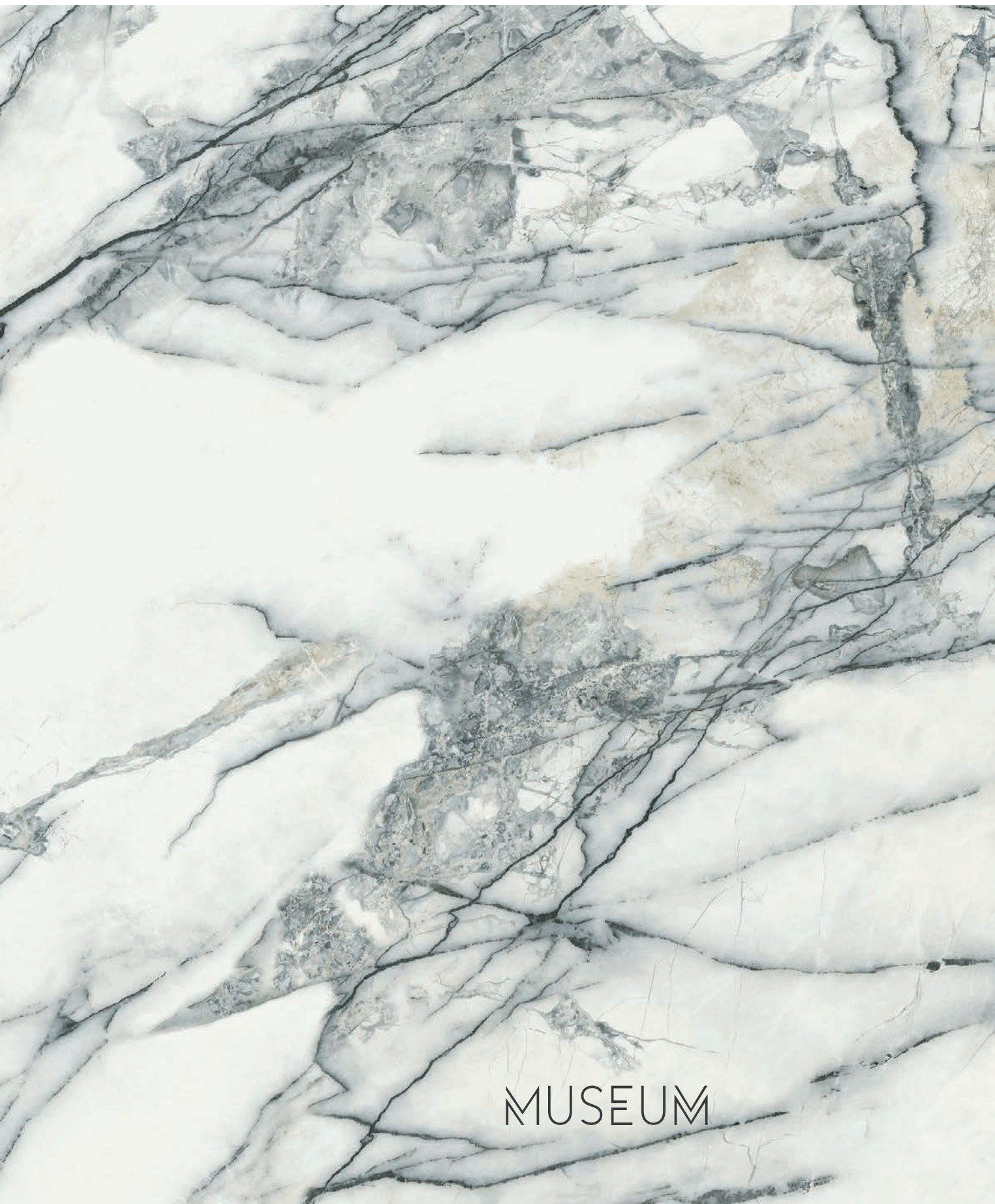

MUSEUM

MUSEUM



04

THE STORY

06

THE COLLECTION

26

MIX&MATCH

28

TECHNICAL INFO

Behind every great ballet spectacle there is a great team making it unforgettable. Hard work, perfectionism and late night rehearsals are what make the difference. We don't stop until everything is ready to come up perfect.

Premiere is a collection worthy of the best stages.

Detrás de cada gran espectáculo de ballet hay un gran equipo que lo hace inolvidable. El trabajo duro, el perfeccionismo y los ensayos nocturnos son los que marcan la diferencia. No nos detenemos hasta que todo está listo para ser perfecto.

Premiere es una colección digna de los mejores escenarios.

PREMIERE

[premiere]

1. A first public performance or showing of a play, opera, film, etc

[estreno]

1. Presentar un espectáculo por primera vez ante el público.

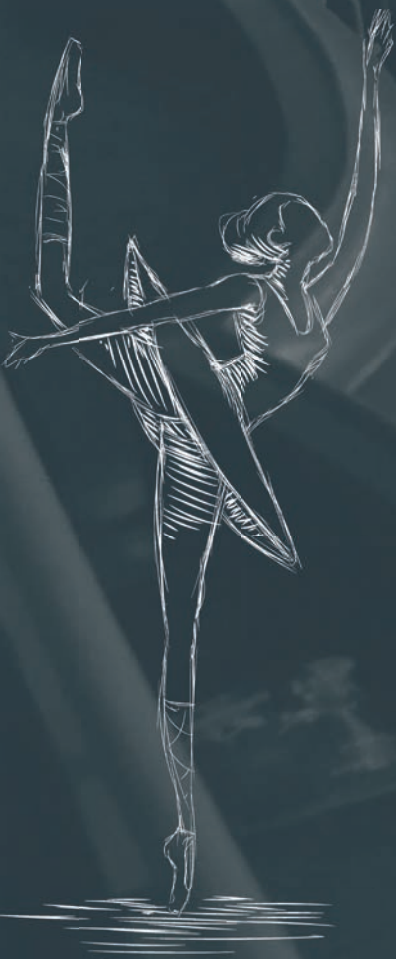



Premiere is an absolute must for design lovers. Inspired by the stone known as *Invisible Marble*, the collection's select design stands out for its anthracite-coloured veins with touches of blue. Combining its dazzling white background and warm shades of beige, Premiere's delicate beauty draws all eyes.

The collection comes in a 100x260cm, 100x180cm or 100x100cm 4D TECH format in a choice of a Premium Polished or Shaped finish and a 75.5x151cm or 60x120cm format in a Polished or Shaped finish.

Premiere surge como una de las colecciones más deseadas para los amantes del diseño. Proviene de la familia de los mármoles invisibles, y su exclusiva gráfica destaca por un veteado antracita con motivos azulados. Representa un conjunto de lo más delicado gracias a la pureza de su fondo blanco y a la calidez de los tonos beige.

Disponibile en formatos 4D TECH 100x260cm, 100x180cm, 100x100cm en acabados Premium Polished y Shaped, y también en 75,5x151cm y 60x120cm en acabados Polished y Shaped.

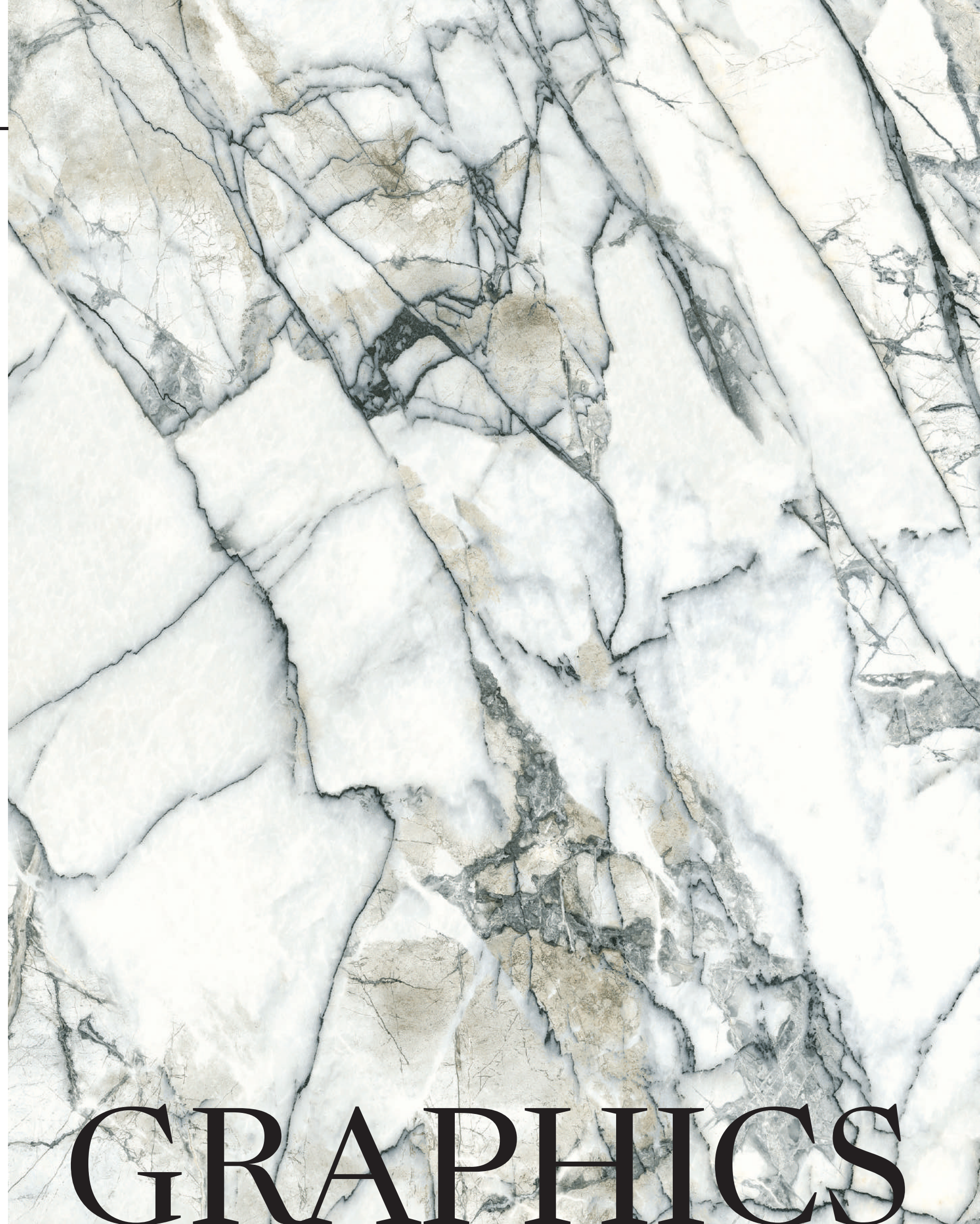

GRAPHICS

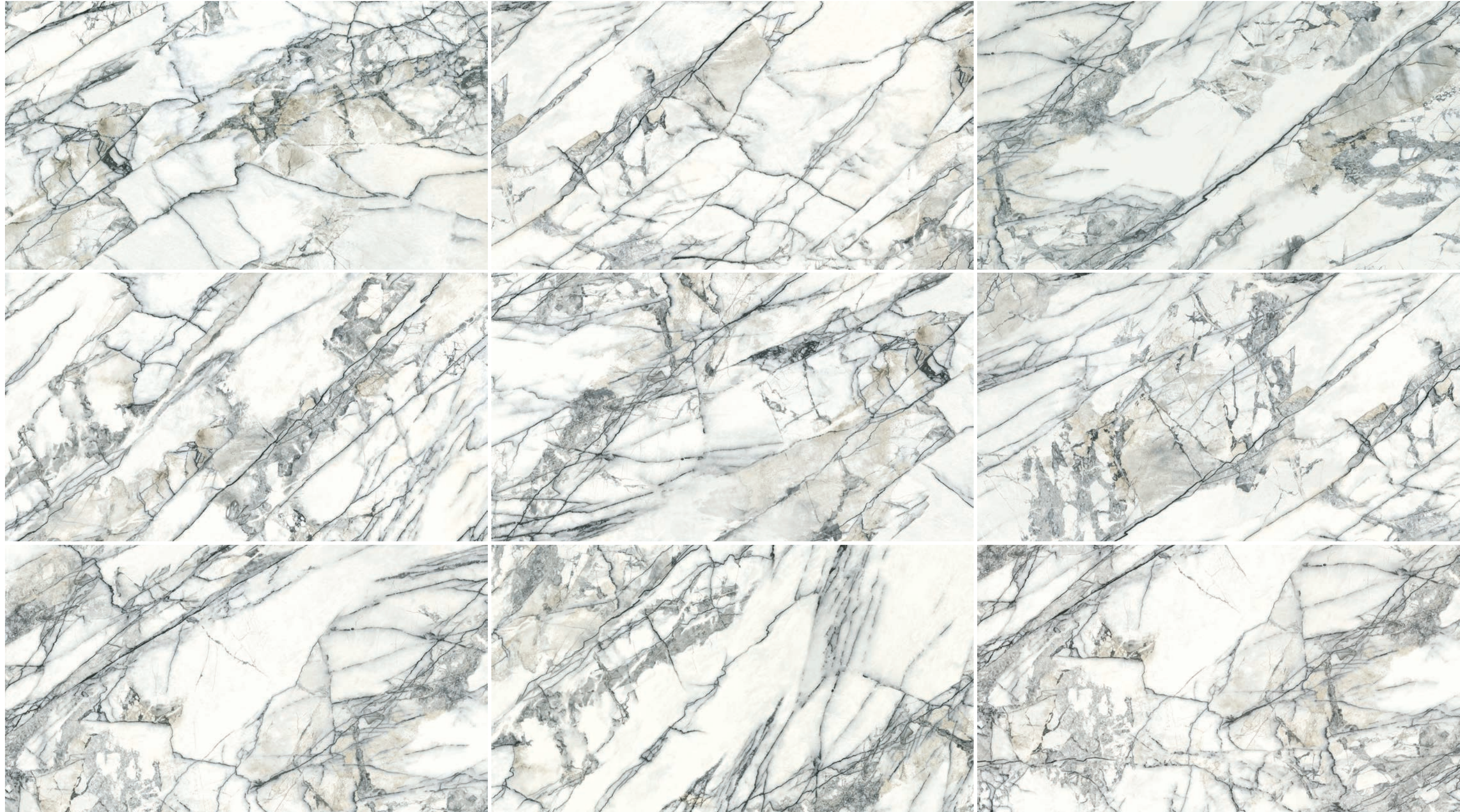

GRAPHIC VARIETY: 12 patterns VARIEDAD GRÁFICA: 12 modelos

Premiere White 100x180 cm



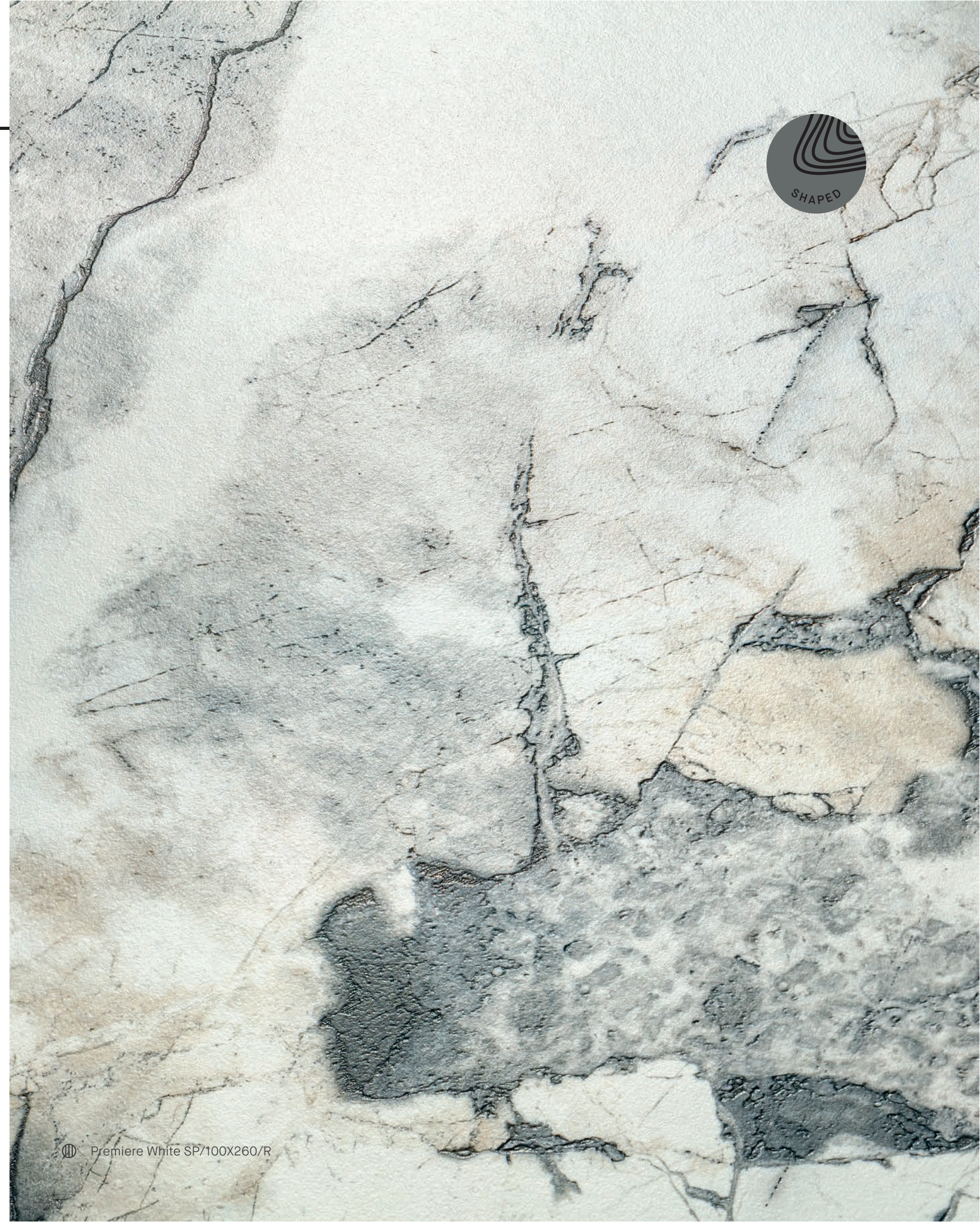







100 x 260 cm



Finish // Acabado



Thickness // Espesor

6 mm

100 x 180 cm



Finishes // Acabados



Thickness // Espesor

8 mm

100 x 100 cm



Finish // Acabado



Thickness // Espesor

8 mm

75,5 x 151 cm



Finishes // Acabados



Thickness // Espesor

10 mm

60 x 120 cm



Finishes // Acabados



Thickness // Espesor

10 mm

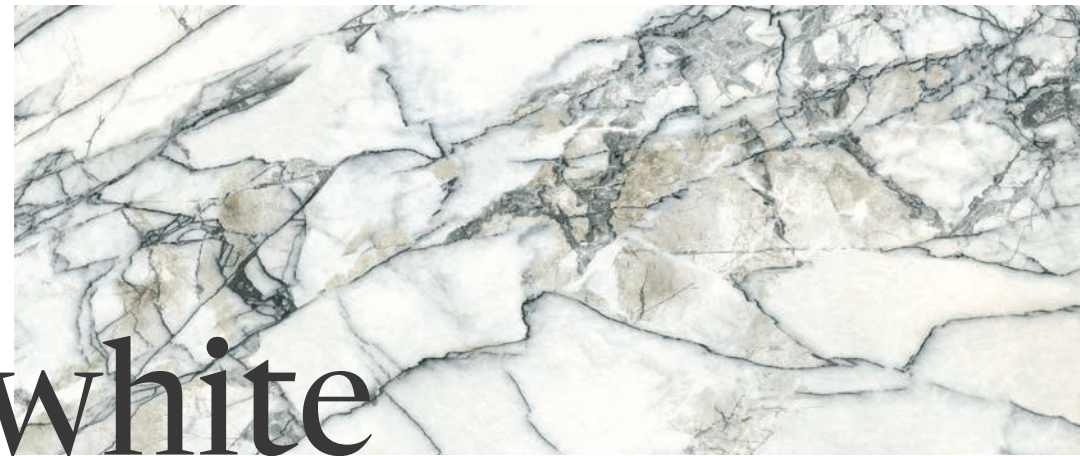

white



COLOUR



premium polished

Polished crystal mirror finish with a perfect reflection.
Available in 4D TECH.

Acabado pulido con un perfecto reflejo especular.
Disponible en 4D TECH.



polished

Polished smooth finish with deep reflection.

Acabado liso pulido con reflejo profundo.

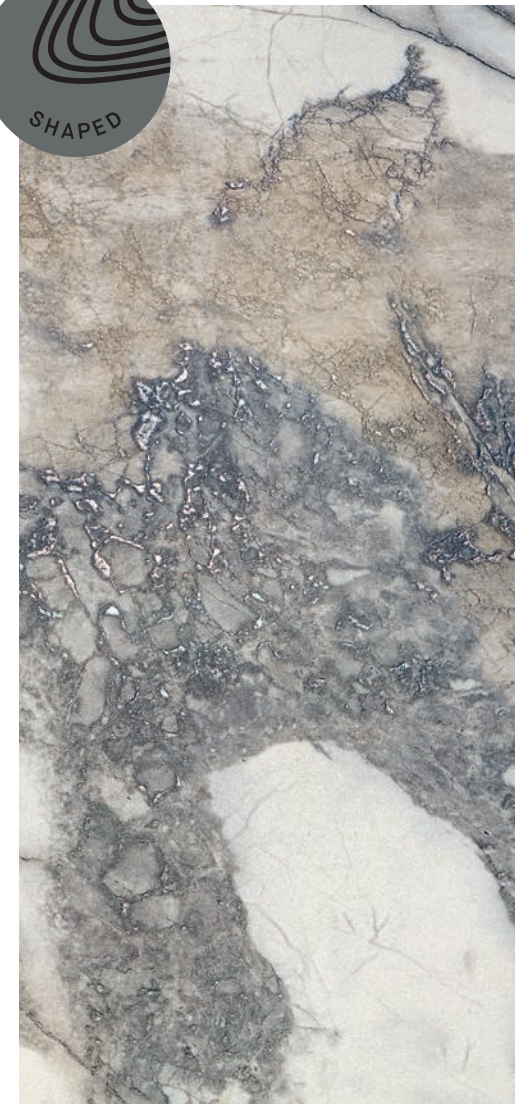

shaped

Smooth texture, the graphic is perfectly coordinated with the relief.

Textura suave, la gráfica se coordina perfectamente con el relieve.

mist



Mist, an oak-effect collection with a chic timeless appeal, is the outcome of constant efforts to innovate.

Available in a 24x151cm format, the collection comes in a choice of a Shaped or Velvet finish. This last finish is the silkiest, most natural tile finish developed to date. Mist also features a choice of 5 warm colours: Maple, Dune, Honey, Kalua and Hazel.

A collection conceived to bring warmth and comfort to living spaces of all kinds, while also adding a select touch of sophistication.

De la constante búsqueda por la innovación, nace Mist, madera de roble natural con una estética atemporal y de lo más sofisticada.

En formato 24x151cm, y con dos acabados Shaped y Velvet. Este último representa la versión más suave y natural conocida hasta el momento en superficie cerámica. Su gama cromática se compone de 5 tonos cálidos: Maple, Dune, Honey, Kalua y Hazel.

Sin duda, la opción acertada para aportar calidez y comodidad a cualquier espacio sin renunciar a un estilo premium.



TECHNICAL INFO

Porcelain Porcelánico

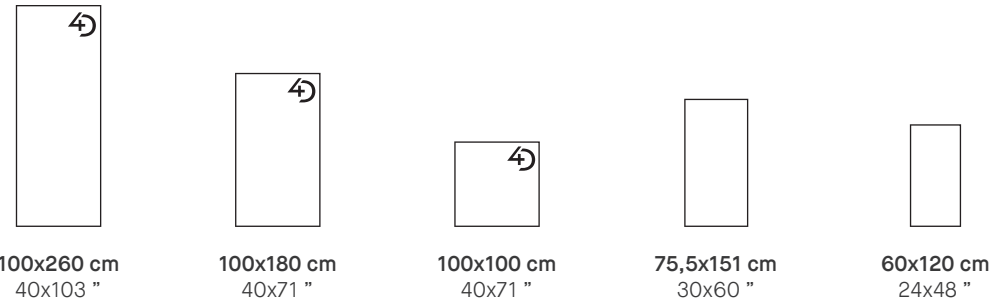

Thickness	6 mm	8 mm		10 mm		
Patterns	8	12	16	16	15	
Shade Variation	V1	V1	V1	V1	V1	
	Shaped (SP)	33116 M100	32932 M94	32931 M93	32930 M103	32929 M101
	Premium Polished (P)	-	32933 M76	-	-	-
	Polished (EP)	-	-	-	32934 M58	32908 M40

SPECIAL PIECES // PIEZAS ESPECIALES

Porcelain Porcelánico (10 mm)

D. MIX	30x30 cm 11.8x11.8 "		
	PREMIERE WHITE MIST HAZEL PREMIERE WHITE	Shaped (SP) Shaped (SP) Polished (EP)	33217 U55

Porcelain Porcelánico (10 mm)

D.CHEVRON	30x21,9 cm 11.8x8.6 "		
	PREMIERE WHITE MIST HONEY	Polished (EP) Shaped (SP)	33209 U55
	PREMIERE WHITE MIST HONEY	Shaped (SP)	33208 U55

TECHNICAL DATA // DATOS TÉCNICOS

	DIN 51130	DIN 51097	UNE-41901 EX	BS 7976-2 (PTV)	ANSI A137.1 (DCOF)
Shaped (SP) 6-8 mm		-	Class 1	-	>0,42 Wet
Shaped (SP) 10 mm	R10	A + B	Class 2	+36 Wet	>0,42 Wet

COMPLEMENTARY PIECES // PIEZAS COMPLEMENTARIAS

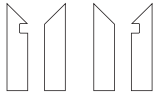
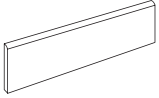
S.K.I.	S.K.D.	SKIRTING					
	8x30 cm 3.1x11.8"		8x100 cm 3.1x39.4"	8x75,5 cm 3.1x29.7"	8x60 cm 3.1x23.6"		
Shaped (SP)	U53	Shaped (SP)	U45	U43	U35		
Premium Polished (P)	U53	Premium Polished (P)	U48	-	-		
Polished (EP)	U53	Polished (EP)	-	U43	U35		

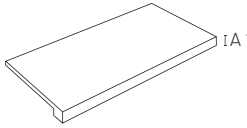
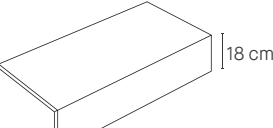
STAIR TREADS		* When thickness is 8 mm, A = 24 mm; when 10 mm, A = 30 mm. * Cuando el espesor es 8 mm, A = 24 mm; cuando es 10 mm, A = 30 mm.					
TECHNICAL (PT)	SEAMLESS (PL/18)	30x180 cm 11.8x70.8"	30x151 cm 11.8x59.4"	30x120 cm 11.8x47.2"	30x100 cm 11.8x39.4"	30x75,5 cm 11.8x29.7"	30x60 cm 11.8x23.6"
							
Shaped (SP)		U90	U86	U75	U74	U76	U54
Premium Polished (P)		U90	-	-	U74	-	-
Polished (EP)		-	U86	U75	-	U76	U54

PACKING // PACKING

SIZE // FORMATO	BOX // CAJA			PALLET			CONTAINER 20' (24000 Kg.)			
	Piezas	m ²	kg	Cajas	m ²	kg	largo x alto x ancho	N° pallets	m ²	kg
100 x 180 x 0,8	2	3,6	70,25	18	64,8	1315	190 x 115 x 60	17	1101,6	22347
100 x 100 x 0,8	2	2	36,8	32	64	1220	112 x 112 x 100	19	1216	23172
75,5 x 151 x 1	1	1,14	26	44	50,16	1189	156 x 93 x 76	17	852,72	20213
60 x 120 x 1	2	1,44	33,18	27	38,88	921	120 x 80 x 75	26	1010,8	23942
inch	Units	ft ²	lb	Boxes	ft ²	lb	length x height x width	N° pallets	ft ²	lb
39,4 x 70,8 x 0,32	2	38,75	154,87	18	697,5	2900	71.2 x 44.1 x 25.2	17	11857,5	49267
39,4 x 39,4 x 0,32	2	21,53	81,13	32	688,9	2690	44.1 x 44.1 x 39.4	19	13088,9	51086
29,7 x 59,4 x 0,39	1	12,27	57,32	44	539,9	2621	61.4 x 36.6 x 29.9	17	9178,6	44562
23,6 x 47,2 x 0,39	2	15,50	73,15	27	418,5	2030	47.2 x 31.4 x 29.5	26	10880,2	52783

SLABS PACKING // PACKING DE PLACAS

SIZE // FORMATO	SLAB // PLACA			WOODEN CRATE // CAJÓN MADERA			CONTAINER 20' (24000 Kg.)			
	Piezas	m ²	kg	Placas	m ²	kg	largo x alto x ancho	Cajones	m ²	kg
100 x 260 x 0,6	1	2,6	36,4	20	52	826,8	278 x 31 x 112 cm	24	1248	19843,2
inch	Units	ft ²	lb	Slabs	ft ²	lb	length x height x width	Crates	ft ²	lb
39,4 x 102,4 x 0,24	1	28	80,25	20	559,7	1822,8	109.4 x 12.2 x 44"	24	13433,4	43746,8

WOODEN CRATE
CAJÓN MADERA
278 x 31 x 112 cm

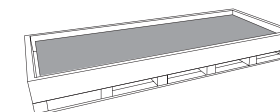

20 slabs placas

20' CONTAINER
optimal load capacity:
Capacidad de carga óptima
del CONTENEDOR 20':

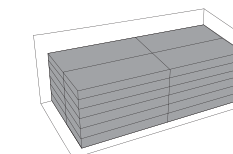

24 crates cajones
6 levels niveles

MUSEUM

Once ceramic tiles reach the end of their useful life, they are inert waste. For their proper management, they should be given to an authorized waste management body for recycling purposes.

All colours and hues appearing in this catalogue should be considered approximate, only in view of the printing processes involved. The rights of all contents (texts, photographs, drawings, designs, etc.) of this catalogue remain the property of PERONDA GROUP S.A (or, failing that, they have the corresponding permissions of the owners). No part of this publication may be reproduced, stored in a retrieval system, or transmitted in any form or by any means, electronic, mechanical, photocopying, recording or otherwise, without the prior written permission of the copyright holders.

© PERONDA GROUP 2022

Las baldosas cerámicas una vez que llegan al final de su vida útil son un residuo inerte, que para su correcta gestión debe ser entregado a un gestor autorizado de residuos, favoreciendo su reciclado.

Av. Manuel Escobedo, 26
12200 Onda (Castellón) Spain
+34 964 602 012

Debido a los procesos de impresión, los colores que aparecen en este catálogo deben considerarse aproximados, y no exactos. Los derechos de todos los contenidos (textos, fotografías, dibujos, diseños etc) del presente catálogo son propiedad de PERONDA GROUP, S.A (o en su defecto, cuentan con los correspondientes permisos y autorizaciones de sus titulares). No está permitida la reproducción total o parcial de esta publicación, ni su tratamiento informático, ni la transmisión de ninguna forma o por cualquier medio, ya sea electrónico, mecánico, por fotocopia, por registro u otros medios, sin el permiso previo y por escrito de los titulares del copyright.

museumsurfaces.com

